

# INSTRUCTION

## FRESH WATER STATIONS FW-EZ40 / FW-E40 / FW-D40 / FW-E60

INSTALLATION AND OPERATING INSTRUCTIONS  
PLEASE READ BEFORE INSTALLATION!



VERSION 04/2026

# Table of contents

Safety instructions . . . . .	3
<b>1. Fresh water stations - Overview . . . . .</b>	<b>7</b>
1.1 Fresh water station FW-EZ 40 . . . . .	8
1.2 Fresh water station FW-E 40 . . . . .	10
1.3 Fresh water station FW-D 40 . . . . .	12
1.4 Fresh water station FW-E 60 . . . . .	14
1.5 Technical specifications . . . . .	16
1.6 Optional accessories . . . . .	17
1.7 Dimensions for wall mounting FW-EZ 40 / FW-E 40 / FW-D 40 . . . . .	18
1.8 Dimensions for wall mounting FW-E 60 . . . . .	19
<b>2. Assembly and installation . . . . .</b>	<b>20</b>
2.1 Assembly . . . . .	20
2.2 Installation . . . . .	20
<b>3. Commissioning . . . . .</b>	<b>21</b>
3.1 Checking the installation . . . . .	21
3.2 Filling the primary circuit . . . . .	21
3.3 Filling the secondary circuit . . . . .	21
3.4 Commissioning the controller . . . . .	21
3.5 Checking the water heating . . . . .	21
3.6 Completing commissioning . . . . .	22
3.7 Handing over the system to the operator . . . . .	22
3.8 For the operator . . . . .	22
3.9 Operation . . . . .	22
<b>4. Resistance table . . . . .</b>	<b>23</b>

# Safety instructions

These instructions are part of the product and contain basic instructions and important information on safety, installation, commissioning, maintenance and optimum use of the appliance.

- Read carefully before use.
- Store during the service life of the product.
- Make it accessible to operating, maintenance and service personnel at all times..
- Pass this on to any subsequent owner, operator or user.

Please also observe the accident prevention regulations applicable in the respective countries, the relevant standards and regulations and the installation and operating instructions for the additional system components. Installation, electrical connection, commissioning and maintenance of the device may only be carried out by a qualified specialist.

**For the operator:** Have a technician give you detailed instructions on how the controller works and how to operate it. Always keep these instructions near the controller.



**Attention**

**For further information on commissioning and using the system, please refer to the enclosed operating instructions „Fresh water Controller MFWC“.**

## Symbols

Warnings are used in these instructions to warn against damage to property and personal injury.



**Danger**

**Failure to observe these instructions may result in life-threatening effects due to electrical voltage.**



**Danger**

**Failure to observe these instructions can result in serious health consequences such as scalds and even life-threatening injuries.**



**Attention**

**Failure to observe these instructions may result in the destruction of the appliance, the system or environmental damage.**



**Attention**

**Information that is particularly important for the function and optimum use of the appliance and the system.**

## Intended use

- The fresh water station should only be used in combination with a buffer tank for heating drinking water in closed heating systems.
- Follow all instructions in this manual and the applicable documents.
- Observe maximum operating limits: see technical data for the respective station.

Any use beyond this is considered improper. The manufacturer is not liable for any damage resulting from this. The user bears the sole risk for this.

## Improper use

Any use other than that specified in these instructions and in the accompanying documents is considered improper. The manufacturer is not liable for any damage resulting from such use. The user bears sole responsibility for this risk.

- Do not connect the fresh water station directly to a heat generator (e.g., boiler or solar circuit).
- Do not use the fresh water station in the following areas: outdoors; damp rooms; rooms where the use of electrical appliances is prohibited; rooms at risk of frost.

# Safety instructions

## Personnel qualification

The fresh water station may only be installed, maintained and repaired by authorized, trained specialists

- Only use qualified personnel who, based on their training and experience, are capable of recognizing risks and avoiding potential hazards.
- Define the responsibilities of personnel according to their qualifications and job descriptions.
- Ensure that the following requirements are met:
  - The personnel have read and understood these operating instructions.
  - The personnel have received instruction on the hazards that may arise.
  - The personnel are familiar with and observe the relevant accident prevention and safety regulations.

## Security measures

Materials and components used on site must be fully suitable for the intended purpose, tested or approved by the manufacturer and must meet the applicable laws, standards, guidelines and regulations.

- Only use appropriate materials and components.
- Do not make any unauthorized changes to the fresh water station.
- The controller of the fresh water station and the pumps are powered by electricity.
- Disconnect the system from the power supply before starting maintenance, servicing and repair work and secure it against being switched back on.
- Keep your workplace clean and free of obstructions.
- Make sure there is sufficient lighting.
- Keep children, pets and unauthorized persons away from tools and assembly areas.
- Store hazardous substances and liquids safely and away from the station area.
- Work on the system should only be carried out by a qualified technician.

### During operation

- If damage occurs to the system:
  - Take the system out of operation.
  - Do not continue to operate the system.

### During maintenance and repair

- Never allow the operator to remove the EPP cover or carry out repairs.
- Only allow repairs to be carried out by a specialist.
- Only use original spare parts.

### Fire protection

- Observe applicable fire protection regulations and valid building codes/building regulations. This applies in particular in the following cases:
  - When penetrating ceilings and walls.
  - In rooms with special/stricter requirements for preventive fire protection measures.

## Residual risks

### Water quality

- Take corrosion protection and scale formation into account in planning in accordance with DIN 1988-7 and drinking water analyses (in accordance with DIN 50930 part 6).
- Check regularly in accordance with DIN 1988.



Attention

#### Station failure due to calcified heat exchanger!

To minimize calcification of the heat exchanger, we recommend installing a water softener at a hardness level of **14°dH** or higher.



Attention

**Please refer to the compatibility table on page 23**

# Safety instructions

## Prevention of property damage

### On-site heating system

- Flush on-site heating systems thoroughly before installing the station.

### Safety equipment in the primary circuit

- Observe VDI guideline 2035 (sheet 1 and 2) during planning, installation and operation.
- Plan and install a safety valve in the primary circuit.

### Safety equipment in the secondary circuit

- Provide a drain pipe for the secondary circuit in accordance with DIN 1988.
- Plan and install a safety valve in the secondary circuit.

### Damage to pumps caused by magnetite deposits

- Please install a magnetite separator.

### Repairs

- Repairs should only be carried out by a qualified technician.
- Only use original replacement parts.

# 1. Fresh water stations - Overview

## Beschreibung Frischwasserstation

### Application

Our fresh water stations FW-EZ 40 / E 40 / D 40 / E 60 heat the drinking water centrally and distribute it to the tapping points via the hot water pipe.

A buffer tank is required to ensure the necessary heating water flow rate. The drinking water is only heated „Just in Time“ when required. **There is no storage of drinking water!**

The fresh water stations are equipped with the **prescribed meter measuring point** and a **meter adapter for meters up to 2,5 Qn**.

### Hot water preparation

The drinking water is heated using the flow principle only when required via a **stainless steel plate heat exchanger**. A special heat exchanger design enables high tap capacities and a low return temperature to the buffer tank.

### High-efficiency pump

A **high-efficiency pump** delivers the volume flow of heating water required for heating from the buffer tank to the plate heat exchanger at a speed-controlled rate.

### Control function

The central control unit is the **electronic control system**. This ensures a constant domestic hot water temperature.

### Sensors

Fast and highly accurate control processes are made possible by the use of state-of-the-art sensors. A **flow sensor based on the vortex principle** determines the flow rate and hot water temperature.

Accurate and fast-responding **PT-1000 temperature sensors** measure the temperatures of the heating return, cold water, buffer tank supply and circulation return.

### Variable return stratification (only for FW-D 40)

The heating return to the buffer tank is connected variably with an **integrated 3-way switching valve**.

At higher return temperatures (e.g., prolonged circulation operation without tapping), stratification occurs in the center of the buffer tank. In normal operation (with tapping), with a very low return temperature, stratification occurs at the bottom of the buffer tank.

The stratification in the buffer tank is maintained. The low buffer tank temperatures required for solar yield in the lower buffer tank area are fully maintained!

### Circulation (only for FW-EZ 40 and FW-D 40)

A **high-efficiency drinking water circulation pump** is intelligently controlled (by pulse, time, and temperature) and speed-controlled by the electronic control system.

### Housing

Elegant EPP insulated housing, designer front, with sturdy instrument panel made of galvanized sheet steel, all drinking water outlets facing upwards.

# 1. Fresh water stations - Overview



**FW-EZ 40**  
Page 8



**FW-E 40**  
Page 10



**FW-D 40**  
Page 12



**FW-E 60**  
Page 14

# 1.1 Fresh water station FW-EZ 40

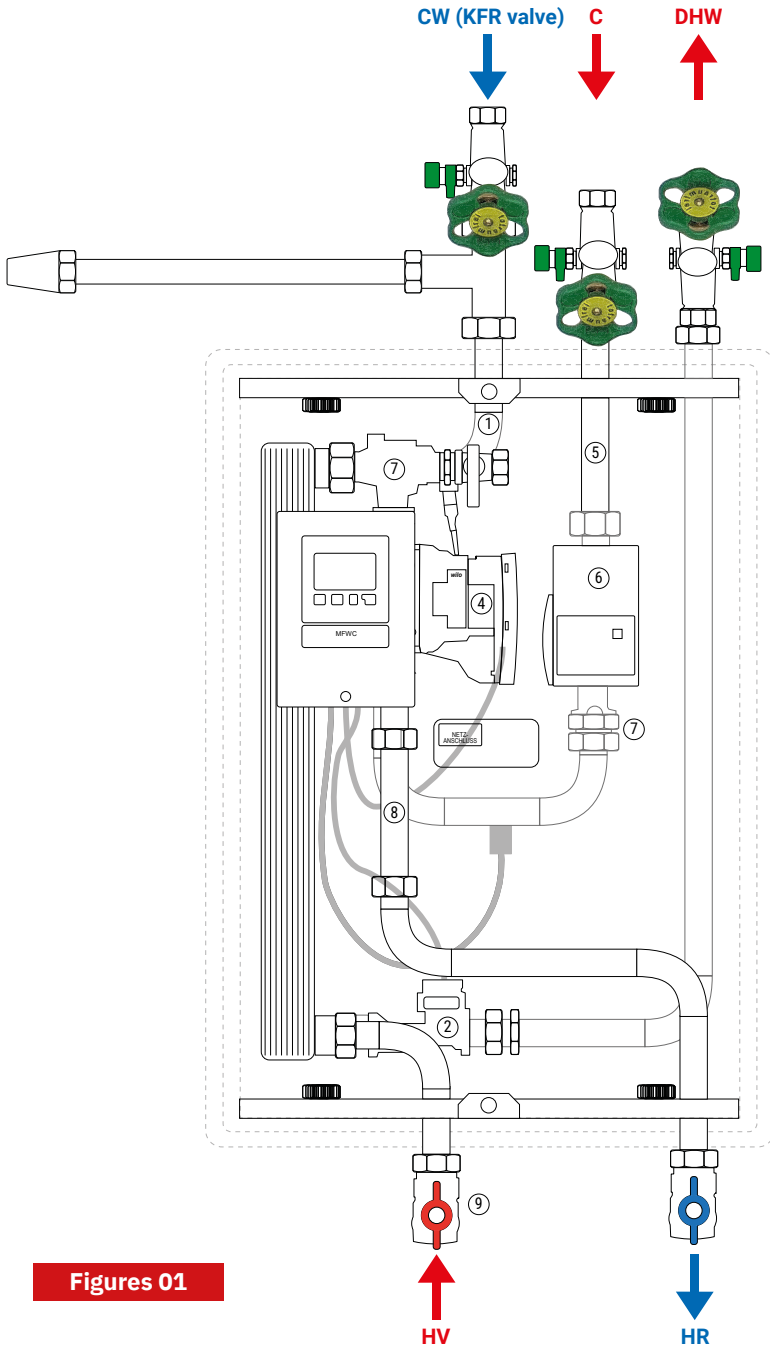

**Figures 01**

# 1.1 Fresh water station FW-EZ 40

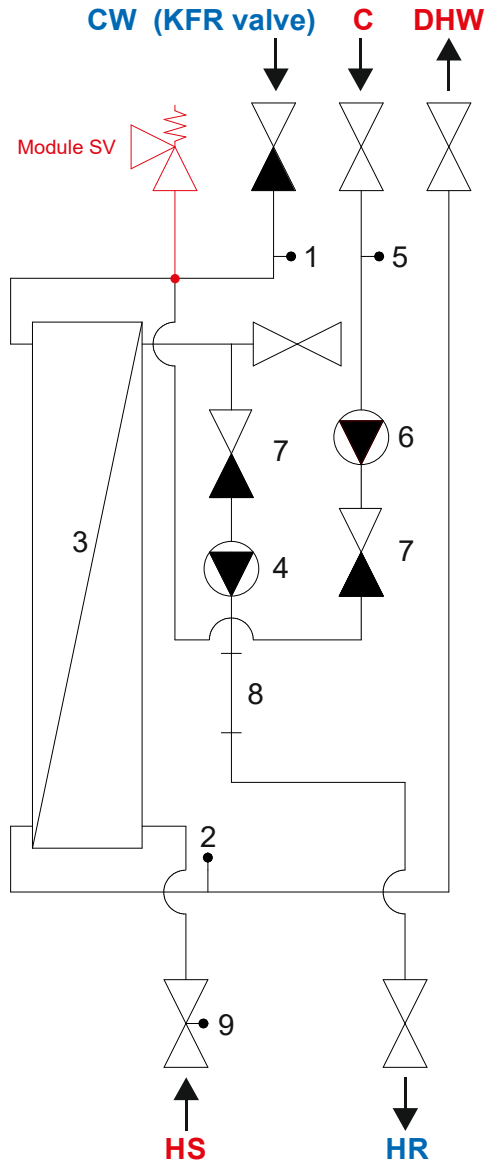

**SCHEMATIC FIG. 01 + 02**

1	Temperature sensor CW
2	Vortex sensor DHW
3	Plate heat exchanger
4	Heating pump
5	Temperature sensor C
6	Circulation pump
7	Backflow preventer
8	Heat meter fitting piece
9	Direct meas. point heat meter
DHW	Hot drinking water
CW	Cold water
HS	Heating Supply
HR	Heating Return
C	Circulation

**Figures 02**

# 1.2 Fresh water station FW-E 40

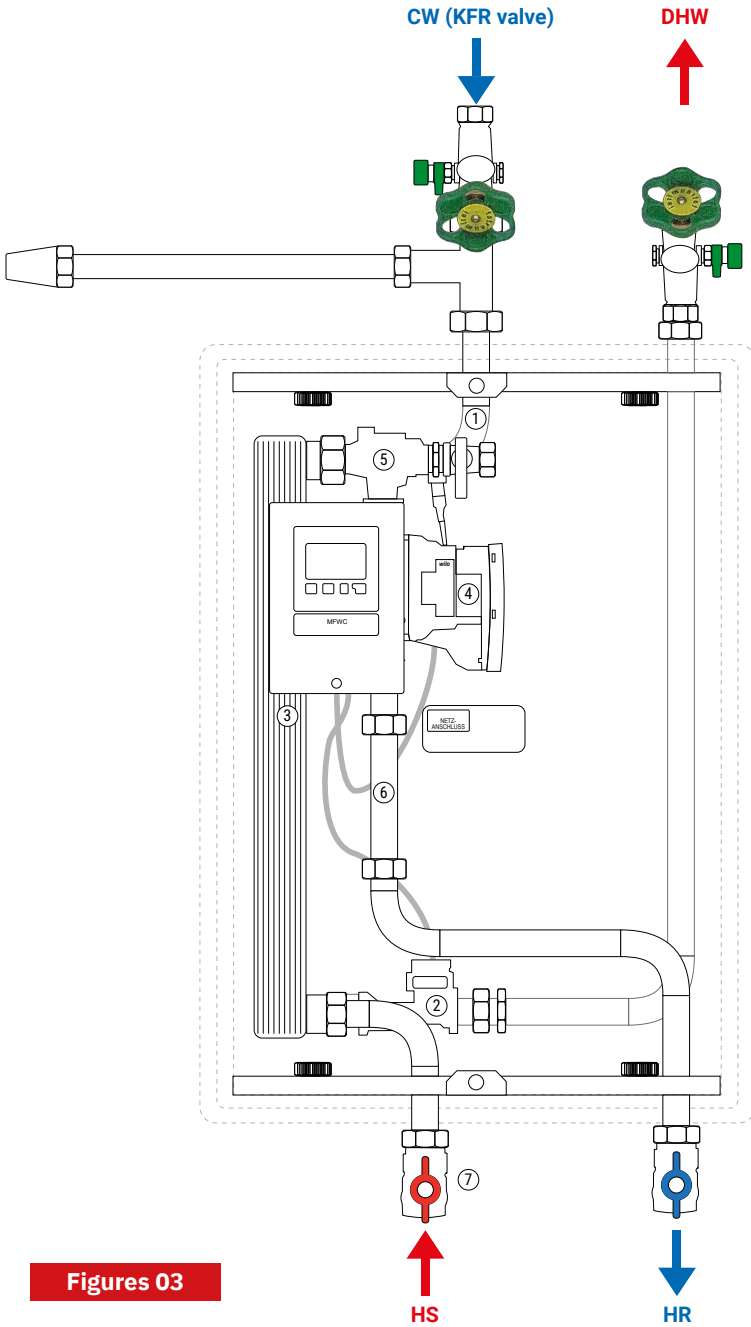

**Figures 03**

# 1.2 Fresh water station FW-E 40

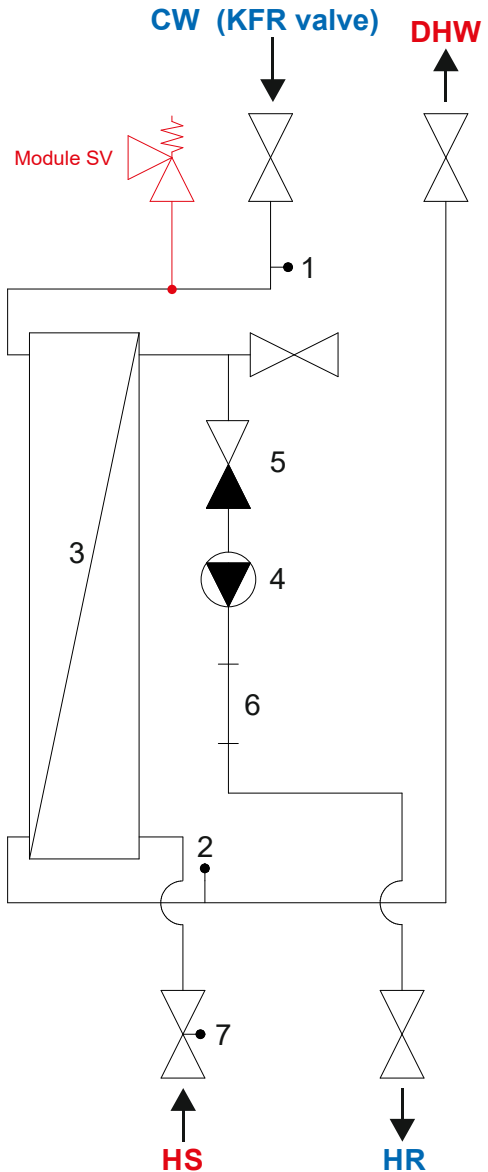

## SCHEMATIC FIG. 03 + 04

- 1      Temperature sensor CW
- 2      Vortex sensor DHW
- 3      Plate heat exchanger
- 4      Heating pump
- 5      Backflow preventer
- 6      Heat meter fitting piece
- 7      Direct meas. point heat meter

**DHW**      Hot drinking water

**CW**      Cold water

**HS**      Heating Supply

**HR**      Heating Return

**Figures 04**

# 1.3 Fresh water station FW-D 40

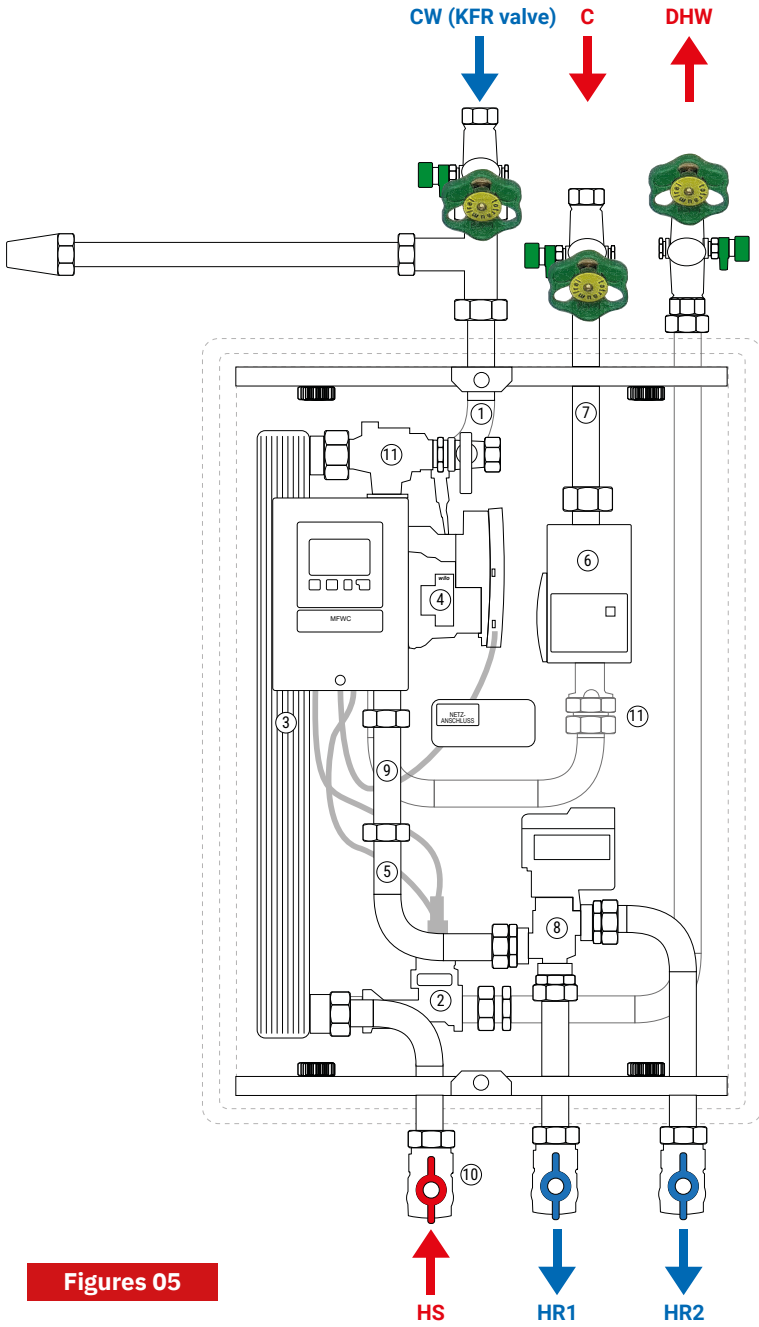

**Figures 05**

# 1.3 Fresh water station FW-D 40

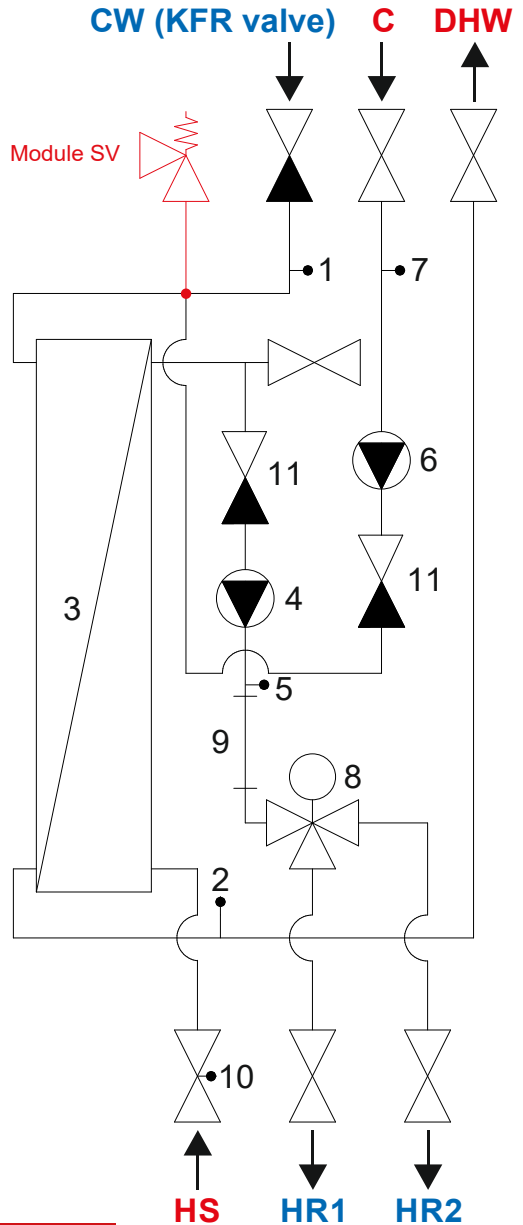

**SCHEMATIC FIG. 05 + 06**

- |            |                               |
|------------|-------------------------------|
| 1          | Temperature sensor CW         |
| 2          | Vortex sensor DHW             |
| 3          | Plate heat exchanger          |
| 4          | Heating pump                  |
| 5          | Temperature sensor HR         |
| 6          | Circulation pump              |
| 7          | Temperature sensor Z          |
| 8          | 3-way switching valve         |
| 9          | Heat meter fitting piece      |
| 10         | Direct meas. point heat meter |
| 11         | Backflow preventer            |
| <b>DHW</b> | Hot drinking water            |
| <b>CW</b>  | Cold water                    |
| <b>HS</b>  | Heating Supply                |
| <b>HR1</b> | Heating Return cold           |
| <b>HR2</b> | Heating return warm           |
| <b>C</b>   | Circulation                   |

**Figures 06**

# 1.4 Fresh water station FW-E 60

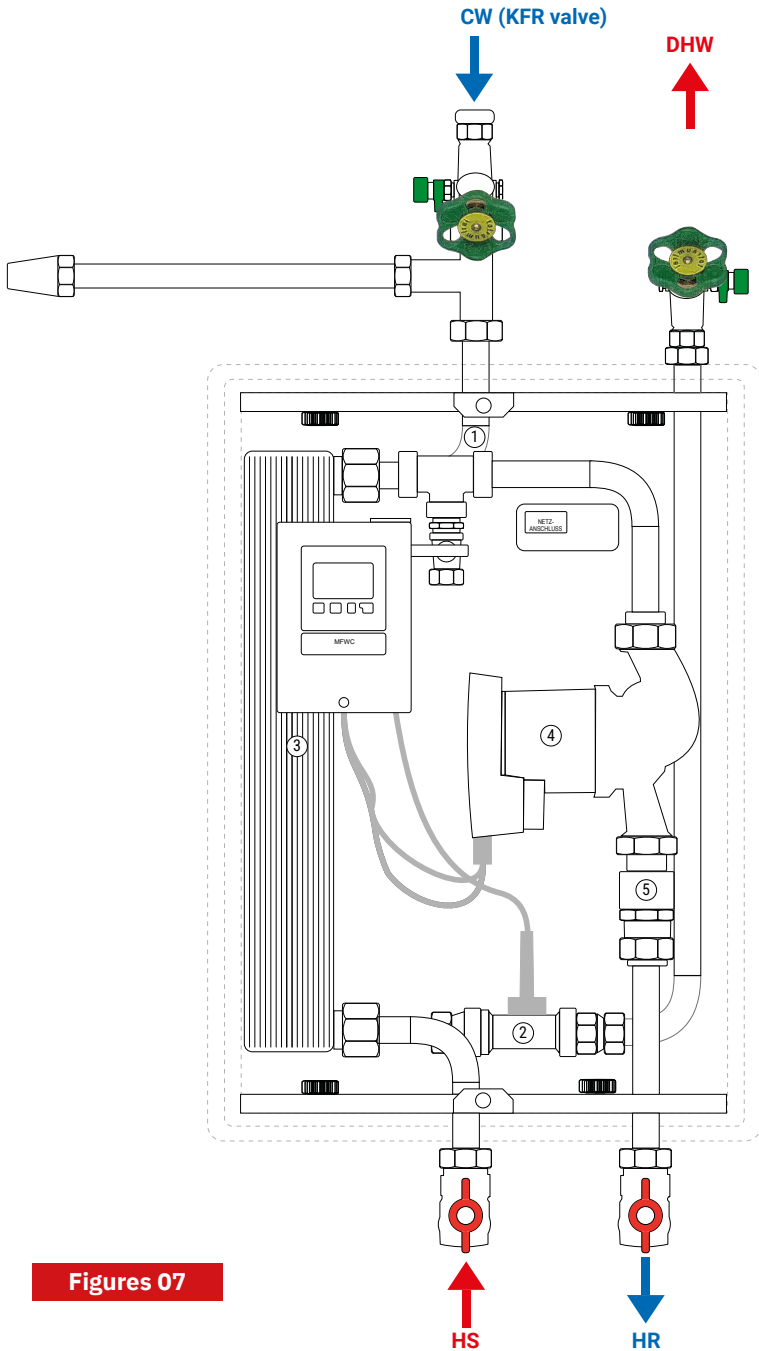

**Figures 07**

# 1.4 Fresh water station FW-E 60

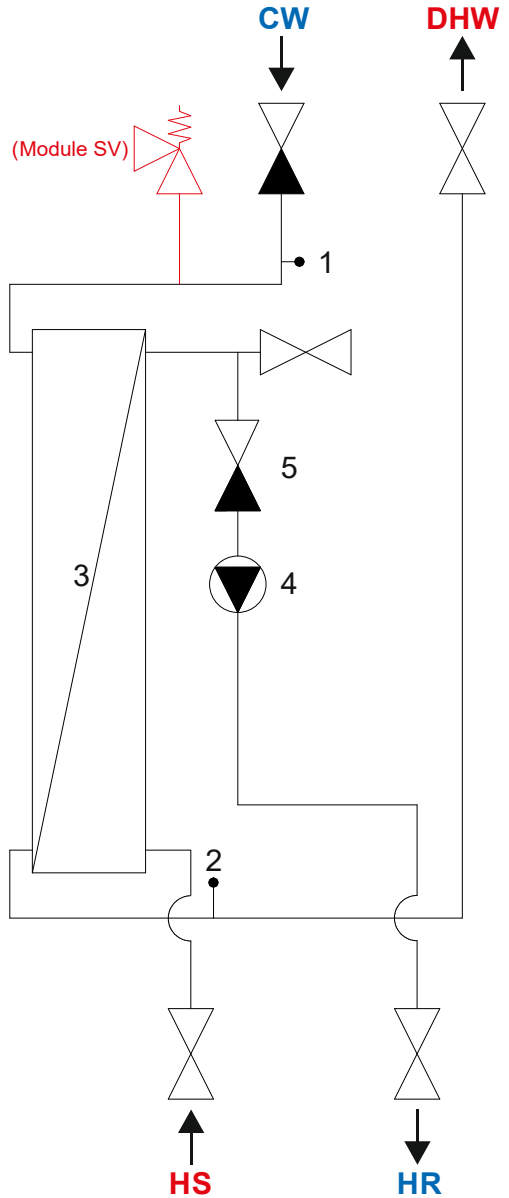

SCHEMATIC FIG. 07 + 08

- 1 Temperature sensor CW
- 2 Vortex sensor DHW
- 3 Plate heat exchanger
- 4 Heating pump
- 5 Backflow preventer

**DHW** Hot drinking water

**CW** Cold water

**HS** Heating Supply

**HR** Heating Return

Figures 08

# 1.5 Technical specifications

	PRIMARY		SECONDARY	
	BUFFER STORAGE		DRINKING WATER	
	FW-EZ / E / D 40	FW-E 60	FW-EZ / E / D 40	FW-E 60
Pressure rating:	PN 6	PN 6	PN 10	PN 6
Max. temperature:	110 °C	110 °C	75 °C	110 °C
Connection dimensions:	DN 25	DN 32	DN 20	DN 20
Thread:	G1" IG	G1¼" IG	G1" AG	G1" AG
Dimensions (WxHxD):	480 x 675 x 240 mm			

PERFORMANCE DATA	PI2*		PI1*	
	FW-EZ / E / D 40	FW-E 60	FW-EZ / E / D 40	FW-E 60
Hot water output:	100 kW	150 kW	100 kW	150 kW
Primary flow rate:	1769 kg/h	2628 kg/h	1745 kg/h	2922 kg/h
Supply temperatures:	70°C	70°C	60°C	60°C
Return temperatures:	22°C	21°C	16°C	16°C
CW / HW temperature:	10°C / 60°C	10°C / 60°C	10°C / 45°C	10°C / 45°C
Flow rate:	28 l/min	42 l/min	36 l/min	61 l/min

**! Attention!** Normal operation guaranteed at 50-75°C, install a pre-mixer if necessary

**\* PI 1 = Performance indicator 1**

at a set hot water temperature of 45°C  
 at a primary flow temperature of 60°C  
 at a cold water temperature of 10°C

**\* PI 2 = Performance indicator 2**

at a set hot water temperature of 60°C  
 at a primary flow temperature of 70°C  
 at a cold water temperature of 10°C

## 1.6 Optional accessories



### Module Z3

#### External drinking water circulation

High-efficiency drinking water circulation pump HE-Z 15-7 PWM 2 with backflow preventer and G1" ball valve.

**Order No. 1000125**



### Module Z4

#### External drinking water circulation

High-efficiency drinking water circulation pump HE-Z 25/1-8 PWM 2 with backflow preventer and G1¼" Y-type valve.

**Order No. 1000126**



### Module Pre-mixer

Pre-mixer set for FW-EZ 40 / E 40 / D 40.

**Order No. 1000132**

# 1.7 Dimensions wall mounting FW-EZ/E/D40

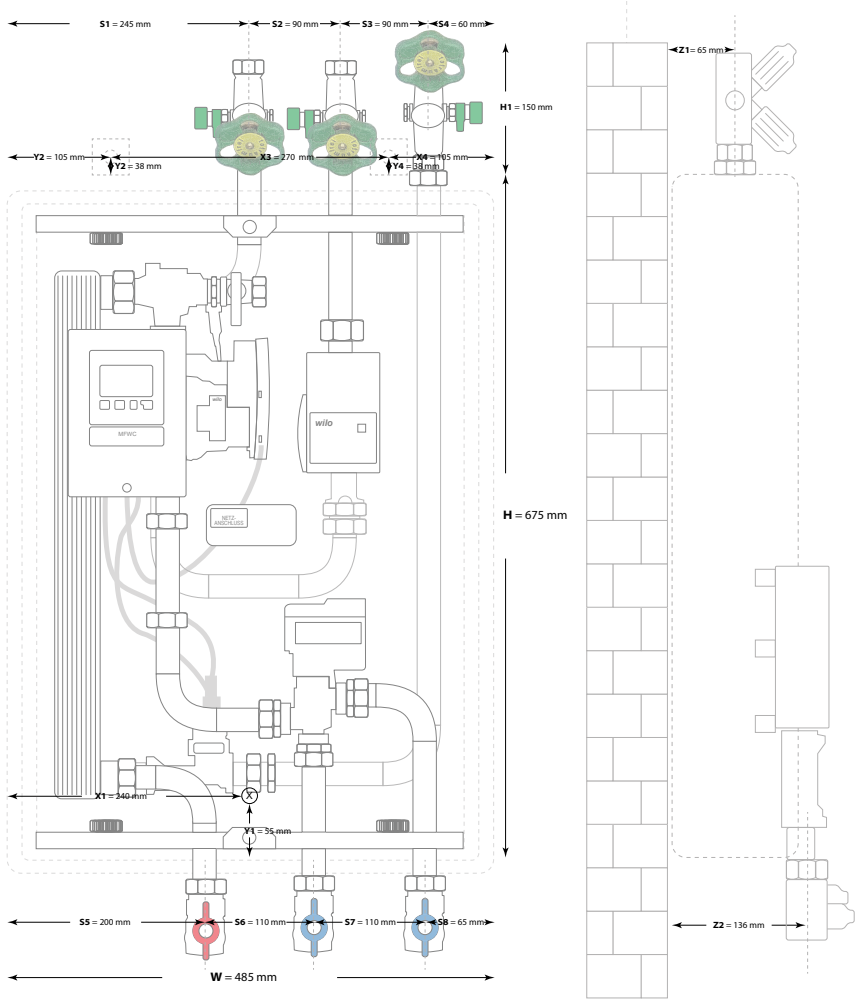

## DIMENSION TABLE

<b>Width W x Height H x Depth D:</b>	485 x 675 x 240 mm	<b>Drill hole positions X, Y:</b>	X1 = 240 mm	Y1 = 55 mm
<b>S1 / S2 / S3 / S4:</b>	245 / 90 / 90 / 60 mm		X2 = 105 mm	Y2 = 38 mm
<b>S5 / S6 / S7 / S8:</b>	200 / 110 / 110 / 65 mm		X3 = 270 mm	
<b>Z1 / Z2:</b>	65 / 136 mm		X4 = 105 mm	Y4 = 38 mm

# 1.8 Dimensions for wall mounting FW-E60

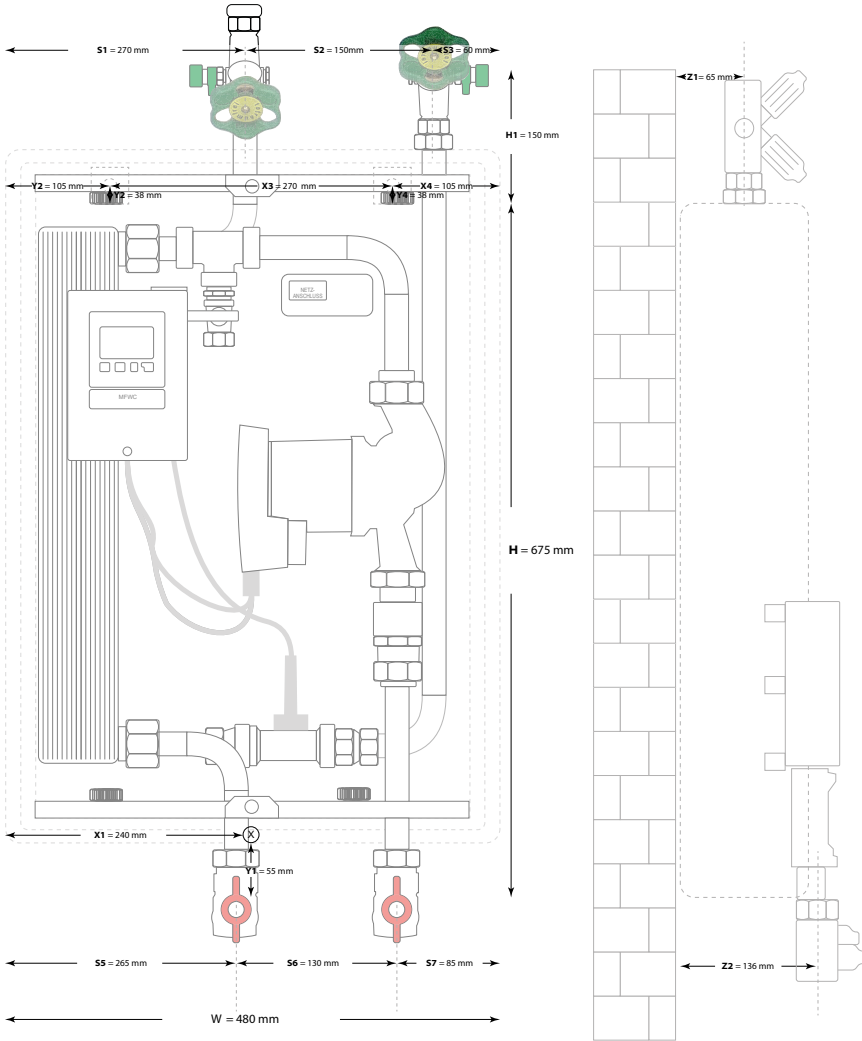

## DIMENSION TABLE

<b>Width W x Height H x Depth D:</b>	480 x 675 x 240 mm	<b>Drill hole positions X, Y:</b>	X1 = 240 mm	Y1 = 55 mm
<b>S1 / S2 / S3 / S4:</b>	270 / 150 / 60 mm		X2 = 105 mm	Y2 = 38 mm
<b>S5 / S6 / S7 / S8:</b>	265 / 130 / 85 mm		X3 = 270 mm	
<b>Z1 / Z2:</b>	65 / 136 mm		X4 = 105 mm	Y4 = 38 mm

## 2. Assembly and installation



### Risk of electric shock

Disconnect the system from the power supply before starting maintenance, servicing and repair work and secure it against being switched back on.



**To prevent damage to the system, the installation site must be dry, stable and frost-free.**

### 2.1 Assembly

1. Determine the installation location for the fresh water station near the buffer tank.
2. The pipes should **not** exceed the lengths specified below (section 2.2).
3. For the drill holes required for installation, please use the dimensions on pages 18/19.
4. Drill the holes and insert the dowels provided. A hanger bolt must be mounted in the wall at the bottom and then secured inside the station with a nut and washer.
5. Remove the station from the packaging.
6. Remove the front insulation shell.
7. Position the fresh water station and secure it with the screws provided. Tighten the screws so that the insulation rests against the wall on both sides.

### 2.2 Installation

Connect the fresh water station to the system as shown in the illustrations on page 8 fig. 01 (FW-EZ 40), page 10 fig. 03 (FW-E 40), page 12 fig. 05 (FW-D 40) or page 14 fig. 07 (FW-E 60).

1. **Primary side return:**  
Return to buffer tank, G1" internal thread connection, piping at least DN 25, maximum length 2 m, for DN 32 maximum length 4 m.
2. **Primary side supply:**  
Supply to buffer tank, G1" internal thread connection, piping at least DN 25, maximum length 2 m, for DN 32 maximum length 4 m.
3. **Secondary side DHW:**  
Hot water outlet, G1" external thread connection, minimum DN 20, flat seal.
4. **Secondary side C:**  
Hot water circulation, Return, G1" external thread connection, flat seal.
5. **Secondary side CW (KFR valve):**  
Hot water inlet, G1" external thread connection, minimum DN 20, flat seal.

# 3. Commissioning



**Attention**

## Damage to pumps due to dry running!

Ensure that the piping is tight.  
Ensure that the pump is filled correctly.



**Attention**

## Damage to pumps due to overpressure!

After completing installation, secure fittings with seals to prevent accidental closure.

### 3.1 Checking the installation

1. Completeness of the piping of the fresh water station.
2. Piping for leaks.
3. Correct installation of safety-related components.

### 3.2 Filling the primary circuit

1. Observe the non-return valve in the storage tank return.
2. Fill and flush the primary circuit.
3. Fill and vent the buffer tank.
4. Vent the primary circuit at the pump, pipes and buffer tank.

### 3.3 Filling the secondary circuit

1. Fill and vent the secondary circuit.



**Attention**

**Note: Fill slowly** and avoid water hammer during filling, as this can damage the vortex sensor.

2. Vent the fresh water station by tapping (cold and hot water side).
3. Vent the circulation pump (only for FW-EZ 40 and FW-D 40).

### 3.4 Commissioning the controller

1. Connect the controller (according to the external instructions for the fresh water controller).
2. Do not close the shut-off valves between the fresh water station and the safety valves while the primary circuit pump is in operation.
3. Start up the controller (the controller is partially preset at the factory).
4. To change the settings, follow the external instructions for the controller.

### 3.5 Checking the water heating

1. Tap hot water.
2. Check water heating.

### 3.6 Completing commissioning

1. Clean the inside of the fresh water station of any construction dirt.
2. Put the cover on.
3. Clean the outside of the system of any construction dirt.

### 3.7 Handing over the system to the operator

1. Instruct the operator of the system in how to operate the system (in accordance with the operating instructions for the controller). Point out safety and maintenance intervals.
2. Note the parameters set during transfer in the protocol.
3. Pass on all instructions to operators:
  - These installation and operating instructions
  - Operating instructions for MFWC fresh water controller

### 3.8 For the operator

Attach all instructions at the installation site of the fresh water station or keep them near the fresh water station.

### 3.9 Operation

Operate the system according to external instructions for controllers.

# 4. Resistance table

The following guide is intended to provide an overview of the corrosion resistance of stainless steels and brazing materials in tap water at room temperature. The table lists several important chemical components, but actual corrosion is a very complex process that is influenced by many different components in combination with each other.

This table is therefore a considerable simplification and should not be overrated!

### Explanations:

- + = Good resistance under normal conditions
- 0 = Corrosion may occur, especially if other factors are rated 0
- = Use not recommended

WATER CONTENT	CONCENTRATION (mg/l or ppm)	TIME LIMITS *	STAINL. STEEL AISI 316	STANDARD PLATE HEAT EXCHANGER **	SPECIAL PLATE HEAT EXCHANGER ***
Alkalinity (HCO <sub>3</sub> <sup>-</sup> )	< 70	Within 24 hours	+	0	+
	70-300		+	+	+
	> 300		+	0/+	+
Sulfate (SO <sub>4</sub> <sup>2-</sup> )	< 70	No limit	+	+	+
	70-300		+	0/-	+
	> 300		+	+	+
HCO <sub>3</sub> <sup>-</sup> / SO <sub>4</sub> <sup>2-</sup>	> 1,0	No limit	+	+	+
	< 1,0		+	0/-	+
Electrical conductivity	< 10 µS/cm	No limit	+	0	+
	70 - 300 µS/cm		+	+	+
	300 - 500 µS/cm		+	0	+
	> 500 µS/cm		+	-	+
pH <sup>[2]</sup>	< 6,0	Within 24 hours	0	0	+
	6,0 - 7,5		+	0	+
	7,5 - 9,0		+	+	+
	> 9,0		+	0	+
Ammonium (NH <sub>4</sub> <sup>+</sup> )	< 2	Within 24 hours	+	+	+
	2 - 20		+	0	+
	> 20		+	-	+
Chloride (CL <sup>-</sup> )	< 100	No limit	+	+	+
	100 - 200		+	+	+
	200 - 300		+	+	+
	> 300		-	0/+	+
Free chlorine (Cl <sub>2</sub> )	< 1	Within 5 hours	+	+	+
	1 - 5		-	0	+
	> 5		-	0/-	+
Hydrogen sulfide (H <sub>2</sub> S)	< 0,05	No limit	+	+	+
	> 0,05		+	0/-	+
Free (aggressive) carbon dioxide (CO <sub>2</sub> )	< 5	No limit	+	+	+
	5 - 20		+	0	+
	> 20		+	-	+
Total hardness (°dH)	4,0 - 8,5	No limit	+	+	+
Nitrate <sup>[1]</sup> (NO <sub>3</sub> <sup>-</sup> )	< 100	No limit	+	+	+
	> 100		+	0	+
Iron <sup>[3]</sup> (Fe)	< 0,2	No limit	+	+	+
	> 0,2		+	0	+
Aluminium (Al)	< 0,2	No limit	+	+	+
	> 0,2		+	0	+
Manganese <sup>[3]</sup> (Mn)	< 0,1	No limit	+	+	+
	> 0,1		+	0	+

<sup>[1]</sup> Sulfates and nitrates act as inhibitors for pitting corrosion caused by chlorides in pH-neutral environments.

<sup>[2]</sup> In general, a low pH value (below 6) increases the risk of corrosion, while a high pH value (above 7.5) reduces the risk of corrosion.

<sup>[3]</sup> SFe<sup>3+</sup> and Mn<sup>4+</sup> are strong oxidizing agents and can increase the risk of local corrosion in stainless steels.

SiO<sub>2</sub> above 150 ppm increases the risk of calcification.

\* Examination time after sample collection

\*\* Standard plate heat exchanger data refers to copper solder joints

\*\*\* Special plate heat exchanger data refers to copper-free solder joints

# 5. Notes

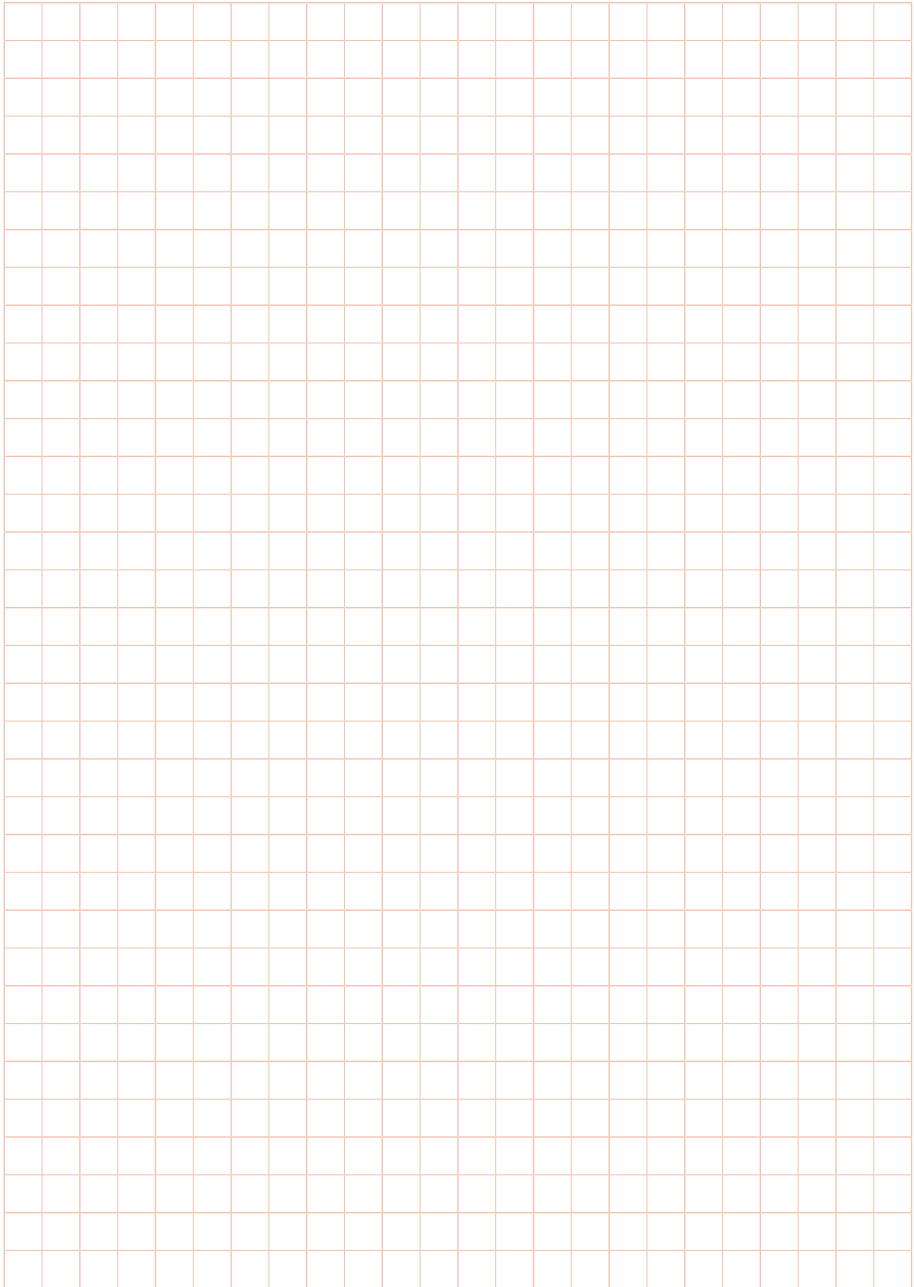

## Strasshofer GmbH

Am Fernblick 11  
08499 Reichenbach  
Germany

Phone: +49 3765 3804 30  
E-Mail: [info@strasshofer.de](mailto:info@strasshofer.de)

Presented by:

